

AGRICULTURAL LINE

GRAIN DRYING



► **APPLICATIONS**

Grain, Corn, and Rice Dryers, Silo Ventilation

The punker **Grain Drying** solution is a series specially developed for silo ventilation and grain drying. The maximum shaft power of the fan wheel is exactly matched to the nominal motor power at nominal motor speed.

Thanks to an efficient inlet cone combination, a very high air output is achieved. The design of this fan wheel with airfoil blade geometry enables low sound power.

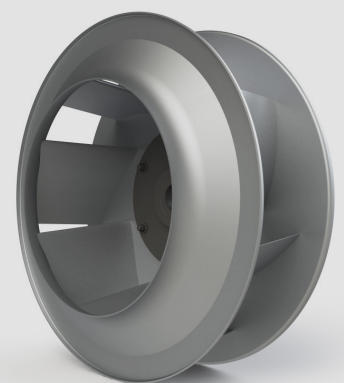

punker GmbH
 Newark 1
 24340 Eckernförde
 Germany
 Fon: +49.4351.472.0
 Fax: +49.4351.472.740
 info@punker.de
 ► www.punker.com

punker LLC
 1112 Lincoln County Pkwy
 Lincolnton, NC 28092
 USA
 Fon: +1.828.322.1951
 Fax: +1.828.328.1336
 info@punker.com
 ► www.punker-usa.com



GRAIN DRYING

SPECIFICATIONS

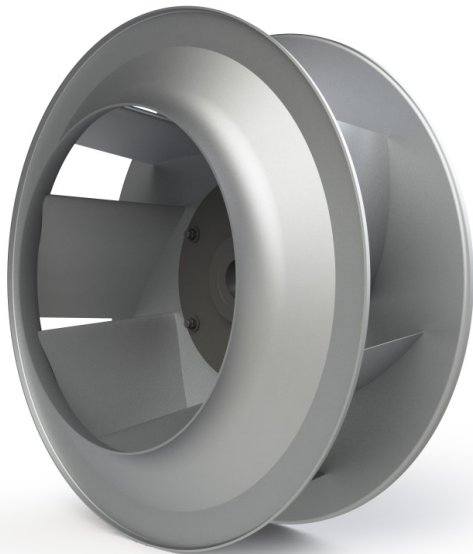

► TECHNICAL DATA

- Material: aluminum
- Installation Type: scroll housing
- Design: single flow
- Direction of rotation:
- clockwise / counterclockwise (R/L)
- Mounting: Taperlock hub system
- Temperature range of 0°C to +50°C (32°F to 122°F), higher or lower range possible after technical clarification
- Durability through cycle fatigue testing
- Half key balance according to ISO 21940-32 (applies to hub-execution only)
- Balance according to ISO 21940-11
- Compatible with various AC/EC motors 50/60Hz
- Models: available in 25 diameter / width combinations for nominal motor power 3 kW - 30 kW / 5 - 50 hp (2-pole or 4 pole)

► CUSTOMER NOTE

- Perform installation and start-up checks
- Designed for continuous operation S1 and service factor 1.0
- Balance check with possible trim balance is recommended
- Checking of frequencies necessary, system resonant frequencies must be avoided
- Installation and start-up should be carried out by qualified personnel only
- For technical information please refer to fan wheels data sheet [0.0.0.01/0.0.0.02](#)
- Use this fan wheel only with the corresponding inlet cone

punker GmbH
Niewark 1
24340 Eckernförde
Germany

Fon: +49.4351.472.0
Fax: +49.4351.472.740

info@punker.de
► www.punker.com

punker LLC
1112 Lincoln County Pkwy
Lincolnton, NC 28092
USA

Fon: +1.828.322.1951
Fax: +1.828.328.1336

info@punker.com
► www.punker-usa.com

GRAIN DRYING

DIMENSIONS

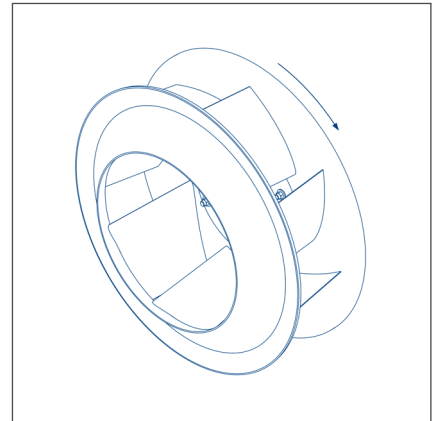
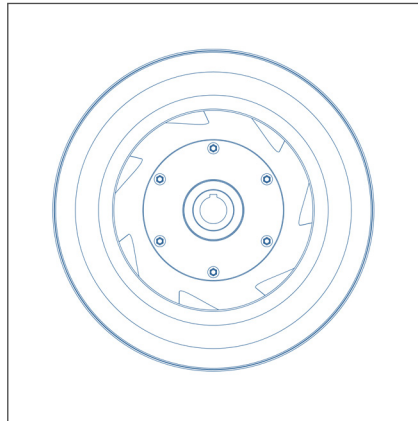
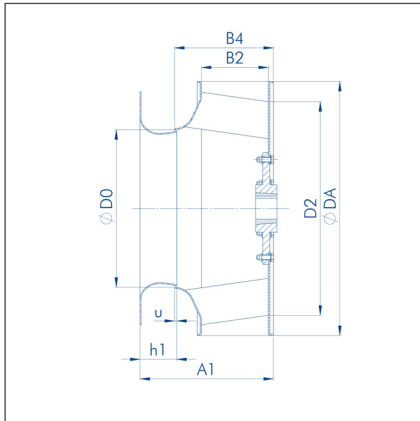

Direction of rotation example: suction
side view: clockwise rotation (R)

FAN WHEEL TYPE EXPLANATION

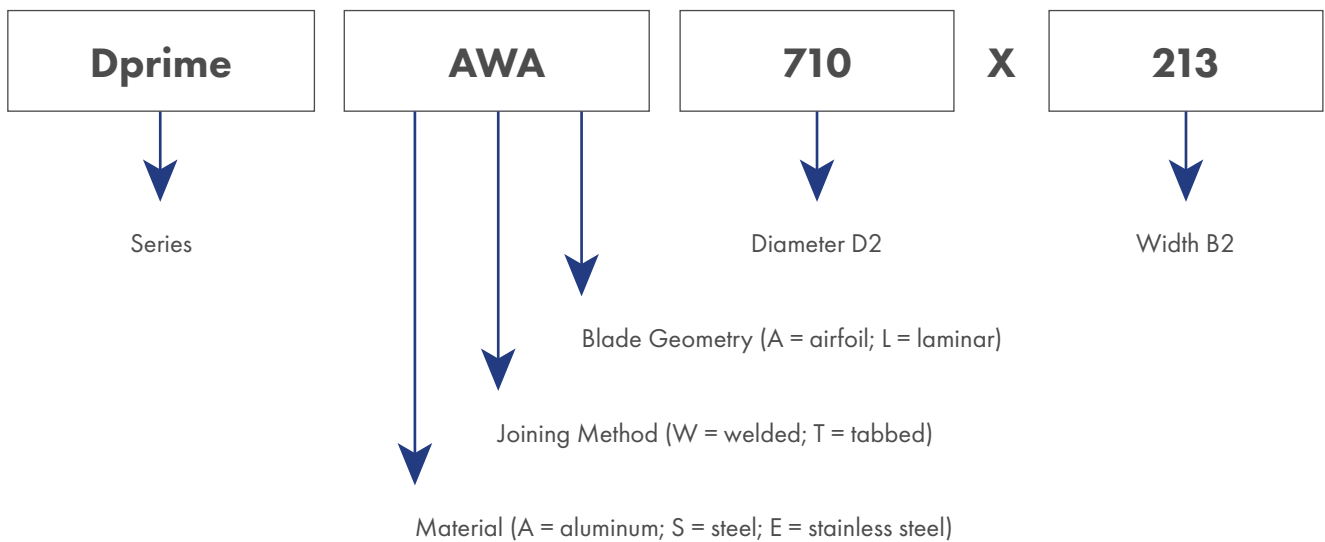

punker GmbH
 Newark 1
 24340 Eckernförde
 Germany
 Fon: +49.4351.472.0
 Fax: +49.4351.472.740
 info@punker.de
 ► www.punker.com

punker LLC
 1112 Lincoln County Pkwy
 Lincolnton, NC 28092
 USA
 Fon: +1.828.322.1951
 Fax: +1.828.328.1336
 info@punker.com
 ► www.punker-usa.com

GRAIN DRYING

METRIC DIMENSIONS

Motor classes			Fan wheel dimensions						Hub assembly dimensions		Inlet cone assembly dimensions For details see sheet: 5.1.331-3.01			
Fre- quency Hz	Power kW	Poles	Type	D2	B2	ØDA	ØD0	B4	Ødmin	Ødmax	Type	h1	u	A1
				mm	mm	mm	mm	mm	mm	mm		mm	mm	mm
50	3	2	Dprime AWA 400x101	400	101	455	282	158,1	14	42	ED11 400	65,7	4,0	220
	4	2	Dprime AWA 400x134	400	134	455	282	191,1	14	42	ED11 400	65,7	4,0	253
	5,5	2	Dprime AWA 450x114	450	114	505	317,3	178,7	19	50	ED11 450	73,6	4,5	248
	7,5	2	Dprime AWA 450x151	450	151	505	317,3	215,7	19	50	ED11 450	73,6	4,5	285
	11	2	Dprime AWA 500x150	500	150	566	352,5	220,5	19	50	ED11 500	82	5,0	298
	3	4	Dprime AWA 560x224	560	224	636	394,8	306,7	24	60	ED11 560	92	5,6	393
	4	4	Dprime AWA 630x181	630	181	716	444,2	275,3	24	60	ED11 630	100	6,3	369
	5,5	4	Dprime AWA 630x252	630	252	716	444,2	346,3	24	60	ED11 630	100	6,3	440
	7,5	4	Dprime AWA 710x213	710	213	806	500,6	317,8	24	60	ED11 710	117	7,1	428
	11	4	Dprime AWA 800x195	800	195	909	564	310,6	28	75	ED11 800	131	8,0	434
	15	4	Dprime AWA 800x269	800	269	909	564	384,6	28	75	ED11 800	131	8,0	508
	18,5	4	Dprime AWA 800x320	800	320	909	564	435,6	28	75	ED11 800	131	8,0	559
	22	4	Dprime AWA 900x237	900	237	1010	634,5	366,2	28	75	ED11 900	148	9,0	505
	30	4	Dprime AWA 900x303	900	303	1010	634,5	432,2	28	75	ED11 900	148	9,0	571
37	4	Dprime AWA 1000x253**	1000	253	1140	705	381,4	28	75	ED11 1000	164	10,0	535	
60	5	2	Dprime AWA 355x106,5	355	106,5	404	250,3	158,2	14	42	ED11 355	59,4	3,6	214
	7,5	2	Dprime AWA 400x110	400	110	455	282	167,1	14	42	ED11 400	65,7	4,0	229
	10	2	Dprime AWA 400x134	400	134	455	282	191,1	14	42	ED11 400	65,7	4,0	253
	15	2	Dprime AWA 450x135	450	135	505	317,3	199,7	19	50	ED11 450	73,6	4,5	269
	3	4	Dprime AWA 500x132	500	132	566	352,5	202,5	19	50	ED11 500	82	5,0	280
	5	4	Dprime AWA 560x147	560	147	636	394,8	229,7	24	60	ED11 560	92	5,6	316
	7,5	4	Dprime AWA 560x224	560	224	636	394,8	306,7	24	60	ED11 560	92	5,6	393
	10	4	Dprime AWA 630x181	630	181	716	444,2	275,3	24	60	ED11 630	100	6,3	369
	15	4	Dprime AWA 710x174	710	174	806	500,6	278,8	24	60	ED11 710	117	7,1	389
	20	4	Dprime AWA 710x239	710	239	806	500,6	343,8	24	60	ED11 710	117	7,1	454
	25	4	Dprime AWA 710x284	710	284	806	500,6	388,8	24	60	ED11 710	117	7,1	499
	30	4	Dprime AWA 800x221	800	221	909	564	336,6	28	75	ED11 800	131	8,0	460
	40	4	Dprime AWA 800x269	800	269	909	564	384,6	28	75	ED11 800	131	8,0	508
	50	4	Dprime AWA 900x220	900	220	1010	634,5	349,2	28	75	ED11 900	148	9,0	488

** In progress

punker GmbH
 Newark 1
 24340 Eckernförde
 Germany

Fon: +49.4351.472.0
 Fax: +49.4351.472.740

info@punker.de
 ► www.punker.com

punker LLC
 1112 Lincoln County Pkwy
 Lincolnton, NC 28092
 USA

Fon: +1.828.322.1951
 Fax: +1.828.328.1336

info@punker.com
 ► www.punker-usa.com

GRAIN DRYING

IMPERIAL DIMENSIONS

Motor classes			Fan wheel dimensions						Hub assembly dimensions		Inlet cone assembly dimensions For details see sheet: 5.1.331-3.01			
Fre- quency Hz	Power kW	Poles	Type	D2	B2	ØDA	ØD0	B4	Ødmin	Ødmax	Type	h1	u	A1
				inch	inch	inch	inch	inch	inch	inch		inch	inch	inch
50	3	2	Dprime AWA 400x101	16	3,98	17,91	11,10	6,22	0,55	1,65	ED11 400	2,59	0,16	8,65
	4	2	Dprime AWA 400x134	16	5,28	17,91	11,10	7,52	0,55	1,65	ED11 400	2,59	0,16	9,95
	5,5	2	Dprime AWA 450x114	18	4,49	19,88	12,49	7,04	0,75	1,97	ED11 450	2,90	0,18	9,76
	7,5	2	Dprime AWA 450x151	18	5,94	19,88	12,49	8,49	0,75	1,97	ED11 450	2,90	0,18	11,21
	11	2	Dprime AWA 500x150	20	5,91	22,28	13,88	8,68	0,75	1,97	ED11 500	3,23	0,20	11,71
	3	4	Dprime AWA 560x224	22	8,82	25,04	15,54	12,07	0,94	2,36	ED11 560	3,62	0,22	15,48
	4	4	Dprime AWA 630x181	25	7,13	28,19	17,49	10,84	0,94	2,36	ED11 630	3,94	0,25	14,53
	5,5	4	Dprime AWA 630x252	25	9,92	28,19	17,49	13,63	0,94	2,36	ED11 630	3,94	0,25	17,32
	7,5	4	Dprime AWA 710x213	28	8,39	31,73	19,71	12,51	0,94	2,36	ED11 710	4,61	0,28	16,84
	11	4	Dprime AWA 800x195	31	7,68	35,79	22,20	12,23	1,10	2,95	ED11 800	5,16	0,31	17,07
	15	4	Dprime AWA 800x269	31	10,59	35,79	22,20	15,14	1,10	2,95	ED11 800	5,16	0,31	19,98
	18,5	4	Dprime AWA 800x320	31	12,60	35,79	22,20	17,15	1,10	2,95	ED11 800	5,16	0,31	21,99
	22	4	Dprime AWA 900x237	35	9,33	39,76	24,98	14,42	1,10	2,95	ED11 900	5,83	0,35	19,89
	30	4	Dprime AWA 900x303	35	11,93	39,76	24,98	17,02	1,10	2,95	ED11 900	5,83	0,35	22,49
37	4	Dprime AWA 1000x253**	39	9,96	44,88	27,76	15,02	1,10	2,95	ED11 1000	6,46	0,39	21,08	
60	5	2	Dprime AWA 355x106,5	14	4,19	15,91	9,85	6,23	0,55	1,65	ED11 355	2,34	0,14	8,43
	7,5	2	Dprime AWA 400x110	16	4,33	17,91	11,10	6,58	0,55	1,65	ED11 400	2,59	0,16	9,01
	10	2	Dprime AWA 400x134	16	5,28	17,91	11,10	7,52	0,55	1,65	ED11 400	2,59	0,16	9,95
	15	2	Dprime AWA 450x135	18	5,31	19,88	12,49	7,86	0,75	1,97	ED11 450	2,90	0,18	10,58
	3	4	Dprime AWA 500x132	20	5,20	22,28	13,88	7,97	0,75	1,97	ED11 500	3,23	0,20	11,00
	5	4	Dprime AWA 560x147	22	5,79	25,04	15,54	9,04	0,94	2,36	ED11 560	3,62	0,22	12,44
	7,5	4	Dprime AWA 560x224	22	8,82	25,04	15,54	12,07	0,94	2,36	ED11 560	3,62	0,22	15,48
	10	4	Dprime AWA 630x181	25	7,13	28,19	17,49	10,84	0,94	2,36	ED11 630	3,94	0,25	14,53
	15	4	Dprime AWA 710x174	28	6,85	31,73	19,71	10,98	0,94	2,36	ED11 710	4,61	0,28	15,30
	20	4	Dprime AWA 710x239	28	9,41	31,73	19,71	13,54	0,94	2,36	ED11 710	4,61	0,28	17,86
	25	4	Dprime AWA 710x284	28	11,18	31,73	19,71	15,31	0,94	2,36	ED11 710	4,61	0,28	19,63
	30	4	Dprime AWA 800x221	31	8,70	35,79	22,20	13,25	1,10	2,95	ED11 800	5,16	0,31	18,09
	40	4	Dprime AWA 800x269	31	10,59	35,79	22,20	15,14	1,10	2,95	ED11 800	5,16	0,31	19,98
	50	4	Dprime AWA 900x220	35	8,66	39,76	24,98	13,75	1,10	2,95	ED11 900	5,83	0,35	19,22

** In progress

punker GmbH
 Newark 1
 24340 Eckernförde
 Germany

Fon: +49.4351.472.0
 Fax: +49.4351.472.740

info@punker.de
 ► www.punker.com

punker LLC
 1112 Lincoln County Pkwy
 Lincolnton, NC 28092
 USA









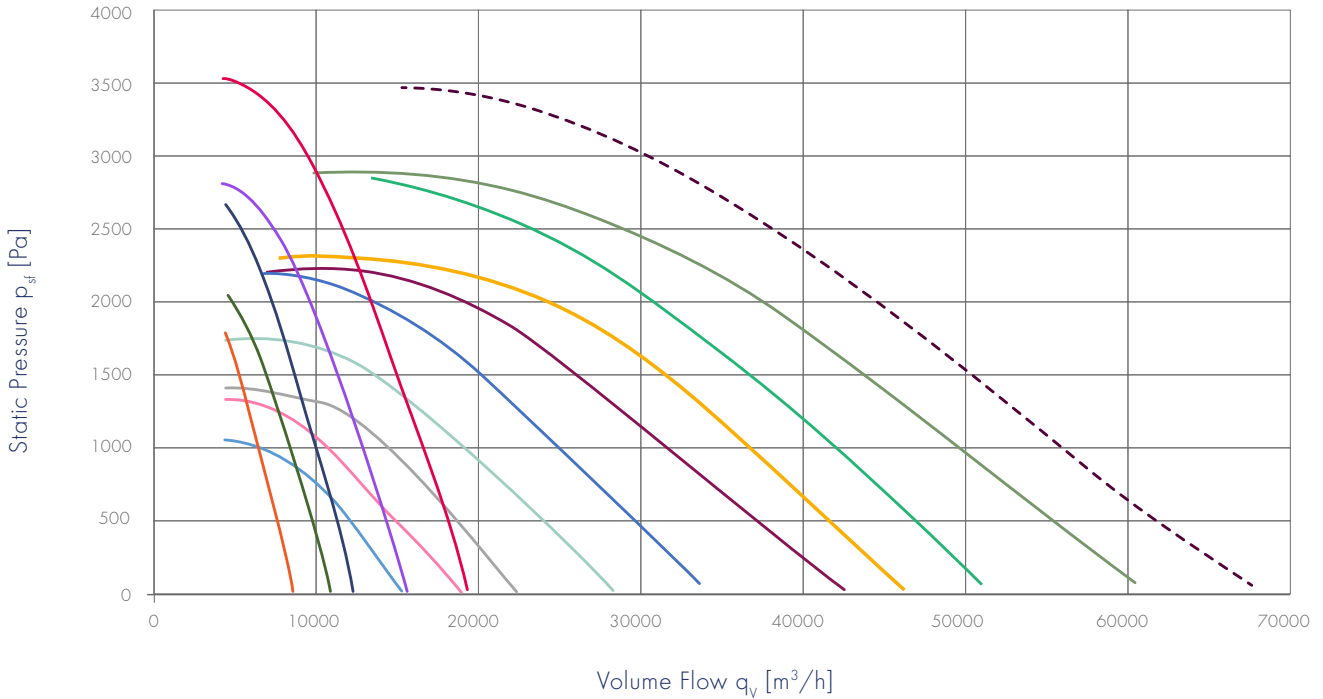





Fon: +1.828.322.1951
 Fax: +1.828.328.1336

info@punker.com
 ► www.punker-usa.com

GRAIN DRYING

CHARACTERISTIC CURVES | 50 Hz*



- | | | |
|---|---|---|
|  3 kW 2 pol 400 x 101 |  4 kW 4 pol 630 x 181 |  15 kW 4 pol 800 x 269 |
|  4 kW 2 pol 400 x 134 |  11 kW 2 pol 500 x 150 |  18,5 kW 4 pol 800 x 320 |
|  5,5 kW 2 pol 450 x 114 |  5,5 kW 4 pol 630 x 252 |  22 kW 4 pol 900 x 237 |
|  7,5 kW 2 pol 450 x 151 |  7,5 kW 4 pol 710 x 213 |  30 kW 4 pol 900 x 303 |
|  3 kW 4 pol 560 x 224 |  11 kW 4 pol 800 x 195 |  **37 kW 4 pol 1000 x 253 |

* Performance curves valid for housing geometry in this data sheet. Reference air density 1,205 kg/m³.
 ** In progress

punker GmbH
 Newark 1
 24340 Eckernförde
 Germany
 Fon: +49.4351.472.0
 Fax: +49.4351.472.740
 info@punker.de
 ► www.punker.com

punker LLC
 1112 Lincoln County Pkwy
 Lincolnton, NC 28092
 USA
 Fon: +1.828.322.1951
 Fax: +1.828.328.1336
 info@punker.com
 ► www.punker-usa.com

GRAIN DRYING

CHARACTERISTIC CURVES | 60 Hz*

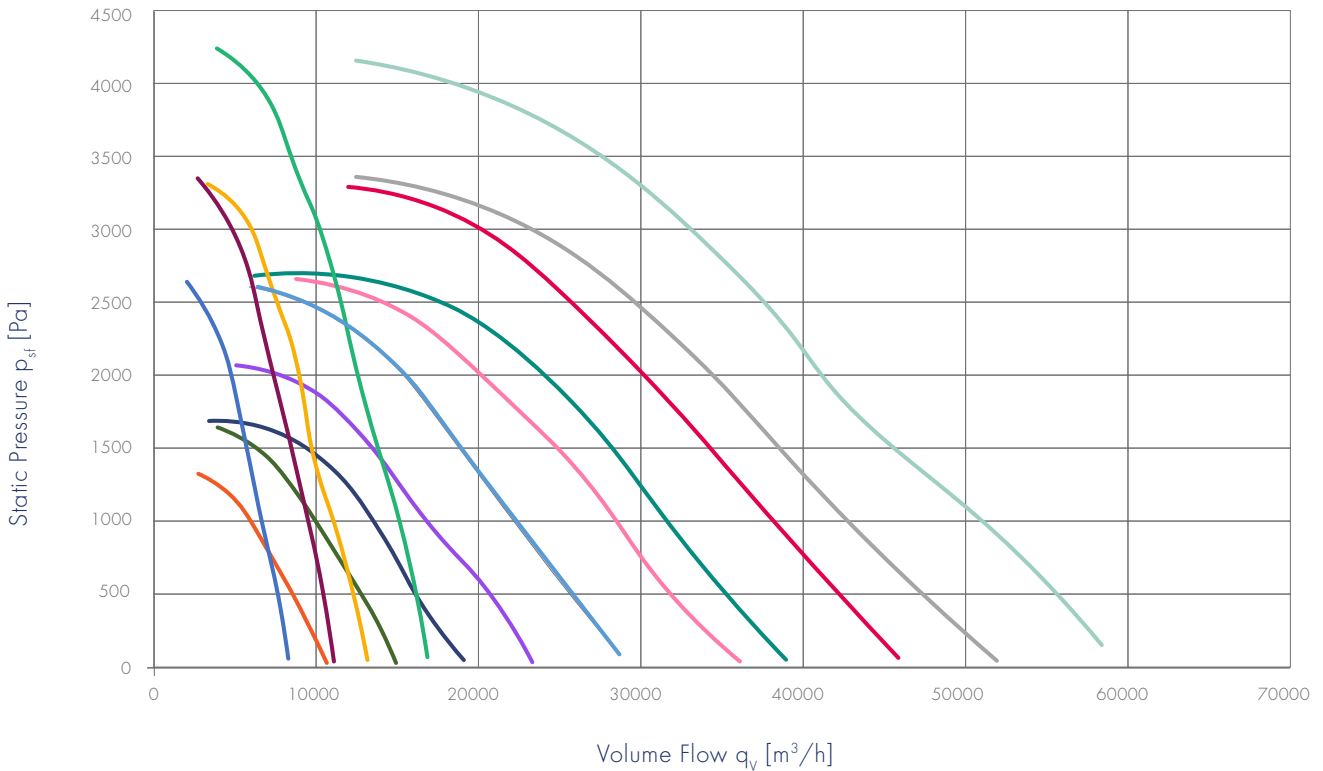

- | | | |
|---|--|---|
| ■ 3 hp 4 pol 500 x 132 | ■ 20 hp 4 pol 710 x 239 | ■ 5 hp 2 pol 355 x 106,5 |
| ■ 5 hp 4 pol 560 x 147 | ■ 25 hp 4 pol 710 x 284 | ■ 7,5 hp 2 pol 400 x 110 |
| ■ 7,5 hp 4 pol 560 x 224 | ■ 30 hp 4 pol 800 x 221 | ■ 10 hp 2 pol 400 x 134 |
| ■ 10 hp 4 pol 630 x 181 | ■ 40 hp 4 pol 800 x 269 | ■ 15 hp 2 pol 450 x 135 |
| ■ 15 hp 4 pol 710 x 174 | ■ 50 hp 4 pol 900 x 220 | |

* Performance curves valid for housing geometry in this data sheet. Reference air density 1,205 kg/m³.

punker GmbH
 Newark 1
 24340 Eckernförde
 Germany

Fon: +49.4351.472.0
 Fax: +49.4351.472.740

info@punker.de
 ► www.punker.com

punker LLC
 1112 Lincoln County Pkwy
 Lincolnton, NC 28092
 USA

Fon: +1.828.322.1951
 Fax: +1.828.328.1336

info@punker.com
 ► www.punker-usa.com

GRAIN DRYING

DIMENSIONS RECOMMENDED HOUSING | METRIC

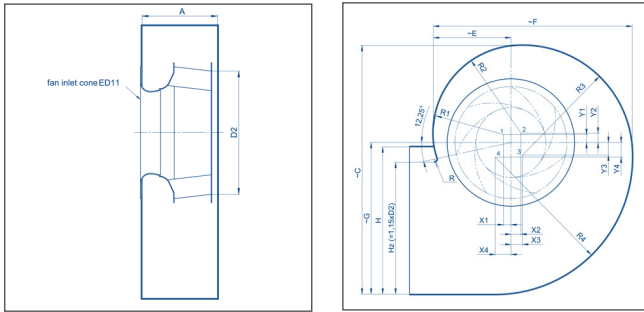

Type	355	400	450	500	560	630	710	800	900	1000**
	mm	mm	mm	mm	mm	mm	mm	mm	mm	mm
D2	355	400	450	500	560	630	710	800	900	1000
H	472	531	598	664	744	837	943	1063	1196	1329
C	788	888	999	1110	1243	1398	1576	1776	1998	2220
E	246	277	312	346	388	436	492	554	623	693
F	630	710	799	888	994	1119	1261	1420	1598	1776
G	480	541	609	677	758	853	961	1083	1218	1353
R	10,1	11,4	12,8	14,3	16,0	18,0	20,2	22,8	25,7	28,5
R1	222,0	250,2	281,4	312,7	350,2	394,0	444,0	500,3	562,9	625,4
R2	277,6	312,8	351,9	391,1	438,0	492,7	555,3	625,7	703,9	782,1
R3	347,2	391,2	440,1	489,0	547,7	616,2	694,4	782,4	880,2	978,0
R4	434,2	489,2	550,4	611,5	684,9	770,5	868,3	978,4	1100,7	1223,0
X1	23,7	26,7	30,1	33,4	37,4	42,1	47,4	53,4	60,1	66,8
X2	31,8	35,8	40,3	44,8	50,1	56,4	63,6	71,6	80,6	89,5
X3	37,0	41,7	46,9	52,2	58,4	65,7	74,1	83,5	93,9	104,3
X4	49,7	56,0	63,0	70,0	78,4	88,2	99,4	112,0	126,0	140,0
Y1	25,4	28,6	32,2	35,8	40,1	45,1	50,8	57,3	64,4	71,6
Y2	29,7	33,4	37,6	41,8	46,8	52,6	59,3	66,8	75,2	83,5
Y3	39,7	44,8	50,4	56,0	62,7	70,5	79,5	89,6	100,8	112,0
Y4	46,3	52,2	58,7	65,2	73,1	82,2	92,6	104,4	117,4	130,5
Inlet cone	ED11 355	ED11 400	ED11 450	ED11 500	ED11 560	ED11 630	ED11 710	ED11 800	ED11 900	ED11 1000

Type	355	400	400	400	450	450	450	500	500	560	560	630	630	710	710	710	710	800	800	800	800	900	900	900	900	1000**
	mm	mm	mm	mm	mm	mm	mm	mm	mm	mm	mm	mm	mm	mm	mm	mm	mm	mm	mm	mm	mm	mm	mm	mm	mm	mm
D2	355	400	400	400	450	450	450	500	500	560	560	630	630	710	710	710	710	800	800	800	800	900	900	900	900	1000
B2	106,5	101	110	134	114	135	151	132	150	147	224	181	252	174	213	239	284	195	221	269	320	220	237	303	253	
A	218	224	233	257	253	274	290	285	303	324	401	375	446	395	434	460	505	440	466	514	565	495	512	578	555	

** In progress

punker GmbH
 Newark 1
 24340 Eckernförde
 Germany

Fon: +49.4351.472.0
 Fax: +49.4351.472.740

info@punker.de
 ► www.punker.com

punker LLC
 1112 Lincoln County Pkwy
 Lincolnton, NC 28092
 USA

Fon: +1.828.322.1951
 Fax: +1.828.328.1336

info@punker.com
 ► www.punker-usa.com

GRAIN DRYING

DIMENSIONS RECOMMENDED HOUSING | IMPERIAL

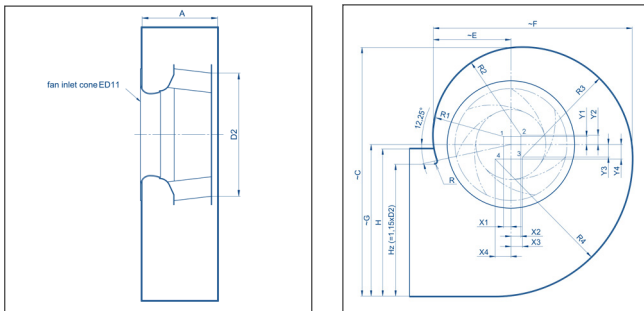

Type	355	400	450	500	560	630	710	800	900	1000**
	inch	inch	inch	inch	inch	inch	inch	inch	inch	inch
D2	14	16	18	20	22	25	28	31	35	39
H	18,57	20,92	23,54	26,16	29,29	32,96	37,14	41,85	47,08	52,31
C	31,02	34,95	39,32	43,69	48,93	55,05	62,04	69,91	78,65	87,38
E	9,68	10,91	12,27	13,63	15,27	17,18	19,36	21,81	24,54	27,27
F	24,82	27,96	31,46	34,95	39,15	44,04	49,63	55,92	62,91	69,91
G	18,92	21,31	23,98	26,64	29,84	33,57	37,83	42,63	47,96	53,29
R	0,40	0,45	0,50	0,56	0,63	0,71	0,80	0,90	1,01	1,12
R1	8,74	9,85	11,08	12,31	13,79	15,51	17,48	19,70	22,16	24,62
R2	10,93	12,32	13,86	15,40	17,24	19,40	21,86	24,63	27,71	30,79
R3	13,67	15,40	17,33	19,25	21,56	24,26	27,34	30,80	34,65	38,50
R4	17,09	19,26	21,67	24,08	26,96	30,33	34,19	38,52	43,34	48,15
X1	0,93	1,05	1,18	1,31	1,47	1,66	1,87	2,10	2,37	2,63
X2	1,25	1,41	1,59	1,76	1,97	2,22	2,50	2,82	3,17	3,52
X3	1,46	1,64	1,85	2,05	2,30	2,59	2,92	3,29	3,70	4,11
X4	1,96	2,20	2,48	2,76	3,09	3,47	3,91	4,41	4,96	5,51
Y1	1,00	1,13	1,27	1,41	1,58	1,78	2,00	2,25	2,54	2,82
Y2	1,17	1,32	1,48	1,64	1,84	2,07	2,33	2,63	2,96	3,29
Y3	1,56	1,76	1,98	2,20	2,47	2,78	3,13	3,53	3,97	4,41
Y4	1,82	2,05	2,31	2,57	2,88	3,24	3,65	4,11	4,62	5,14
Inlet cone	ED11 355	ED11 400	ED11 450	ED11 500	ED11 560	ED11 630	ED11 710	ED11 800	ED11 900	ED11 1000

Type	355	400	400	400	450	450	450	500	500	560	560	630	630	710	710	710	710	800	800	800	800	900	900	900	1000**
	inch	inch	inch	inch	inch	inch	inch	inch	inch	inch	inch	inch	inch	inch	inch	inch	inch	inch	inch	inch	inch	inch	inch	inch	inch
D2	14	16	16	16	18	18	18	20	20	22	22	25	25	28	28	28	28	31	31	31	31	35	35	35	39
B2	4,19	3,98	4,33	5,28	4,49	5,31	5,94	5,20	5,91	5,79	8,82	7,13	9,92	6,85	8,39	9,41	11,18	7,68	8,70	10,59	12,60	8,66	9,33	11,93	9,96
A	8,58	8,82	9,17	10,12	9,96	10,79	11,42	11,22	11,93	12,76	15,79	14,76	17,56	15,55	17,09	18,11	19,88	17,32	18,35	20,24	22,24	19,49	20,16	22,76	21,85

** In progress

punker GmbH
 Newark 1
 24340 Eckernförde
 Germany

Fon: +49.4351.472.0
 Fax: +49.4351.472.740

info@punker.de
 ► www.punker.com

punker LLC
 1112 Lincoln County Pkwy
 Lincolnton, NC 28092
 USA

Fon: +1.828.322.1951
 Fax: +1.828.328.1336

info@punker.com
 ► www.punker-usa.com